

# PETRACARBON PTE LTD

1001 JALAN BUKIT MERAH  
#04-01/06 REDHILL INDUSTRIAL ESTATE  
SINGAPORE 159455  
Fax: (65) 6273 3121 Tel: (65) 6271 0800  
Website: www.petracarbon.com

## J900i Flange Facer 150mm ~ 964mm (6" ~ 34")

**BOLTITTE**

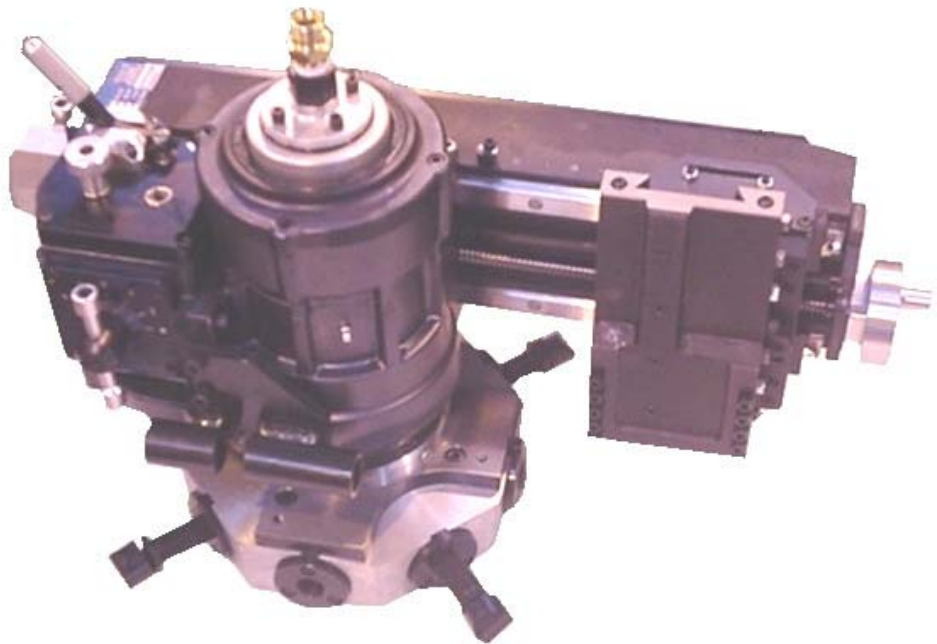

- ❖ Linear ball guideways and ballscrew
  - ❖ Facing with continuous groove (8 feeds)
  - ❖ Boring with continuous groove (8 feeds)
  - ❖ Toolpost 360° swivel power feed
  - ❖ RTJ 'V' grooves
  - ❖ Lens Ring Joints
  - ❖ Ring Joints
  - ❖ Weld Preps
  - ❖ Finishes from: 0.6µm ~ 8µm (facing)  
0.25µm ~ 32µm (boring)
- } All under power feed  
(No additional kits required)

# PETRACARBON PTE LTD

1001 JALAN BUKIT MERAH  
 #04-01/06 REDHILL INDUSTRIAL ESTATE  
 SINGAPORE 159455  
 Fax: (65) 6273 3121 Tel: (65) 6271 0800  
 Website: www.petracarbon.com

## J900i Flange Facer – Technical Specification

### General Description

J900i Flange Facer is an internally mounted machine with four speed continuous feed gearbox, facing/boring and weld prep machine. This Facer has a unique twin shaft power feed long series toolpost. A separate power take off permits the use of attachments for grinding/milling (options). J900i runs on precision ball leadscrew system.

### Dimensions

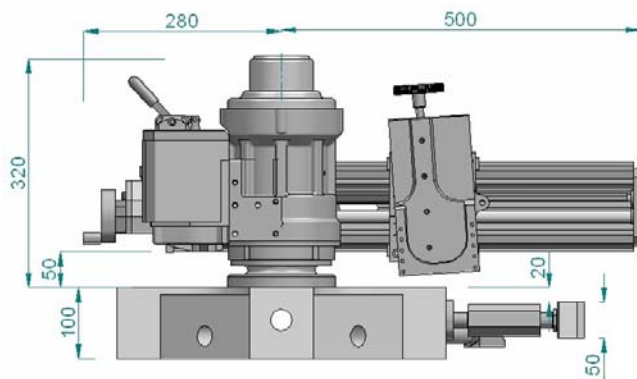

### Range

- ❖ Minimum facing dia. : 150mm (6")
- ❖ Maximum facing dia. : 860mm (34")
- ❖ Minimum clamping dia. : 50mm (6")
- ❖ Maximum clamping dia. : 508mm (34")
- ❖ Toolpost travel (vertical): 100mm (4")
- ❖ Toolpost swivel angle : 360° (power feed @ any angle)

### Drive

- ❖ Pneumatic @ 90psi (6bar) : 1.55Hp (1.11Kw)
- ❖ Air consumption / supply required : 48scfm (1.35m<sup>3</sup>/m) @ 90psi (6bar)
- ❖ RPM : 33 approx. maximum

### Feed Rates

- ❖ Facing feeds : 0.10 ~ 0.81mm (fine ~ coarse)
- ❖ Boring feeds : 0.03 ~ 0.25mm (fine ~ coarse)

### Weights

- ❖ Machine Weight : 40kg (88lb)
- ❖ Shipping Weight : 168kg (370lb)
- ❖ Shipping Dimensions (L x W x H) : 71.1cm x 43.2cm x 68.6cm (28" x 17" x 27")

### Optional

- ❖ 'V' Groove measuring trammels
- ❖ 20° lens ring polishing kit
- ❖ Tube sheet back facing kit
- ❖ Spare kit
- ❖ Hydraulic motor
- ❖ Hydraulic power pac